



AE-3s2

LOUDSPEAKER SYSTEM

DESCRIPTION:

The AE-3s2 two-way, single-amped system produces high acoustic output from a small enclosure. A pair can cover large hotel ballrooms or auditoriums for speech reproduction; adding an optional subwoofer provides wide-range music reproduction.

DRIVER COMPLEMENT:

LOW FREQUENCY: One Apogee 10" (254mm) permanent magnet cone-type driver is treated with a waterproofing compound, providing resistance to moisture, and enabling long-term stability of cone resonance and cone mass parameters

HIGH FREQUENCY: One Apogee 1" (25mm) horn-loaded compression driver

INPUT CONNECTORS:

Neutrik™ NL4 MP Speakon™ connectors standard; Cannon EP series and gas-tight barrier strips optional

COMPATIBLE PROCESSORS:

DLC24 Digital Controller

HANDLES:

Two handles designed as an integral part of enclosure (no moving parts)

GRILLE:

Powder-coated, diamond-punched steel with acoustic foam covering

RIGGING HARDWARE:

Two 12-gauge steel nutplates, mounted one on either side, recessed, nominally flush; accepts 3/8"-16 thread, (10mm nutplate optional); nutplates are backed with 12-gauge steel internal brackets

FINISH:

Textured high-strength black epoxy paint; other colors optional

ENCLOSURE TYPE:

20° trapezoidal, optimally-vented bass

CABINET CONSTRUCTION:

Multi-ply birch with stainless steel fasteners

ENGINEERING DATA:

FORMAT:

Single-amped/Two-way/Electronically-coupled

DISPERSION:

H: 70° x V: 45°

FREQUENCY RESPONSE (1M ON AXIS):

70 Hz to 18 kHz ± 3 dB

MAX. SPL (@1M):

124 dB cont./130 dB peak

PTML (PEAK TRANSIENT MECHANICAL LIMIT):

138 dB

SENSITIVITY (1W @ 1M):

99.5 dB/200 Hz to 4 kHz

NOMINAL IMPEDANCE:

8 ohms

MAX. POWER HANDLING:

300W cont./1200W peak

DIMENSIONS:

front: 12.5" (318mm) W x 16.25" (413mm) H

rear: 10" (254mm) W x 16.25" (413mm) H

depth: 10" (254mm)

WEIGHT:

36 lb. (16.4 kg)

APOGEE
SOUND INTERNATIONAL, LLC

POLAR MEASUREMENTS AE-3S2 (6 dB/division, normalized)

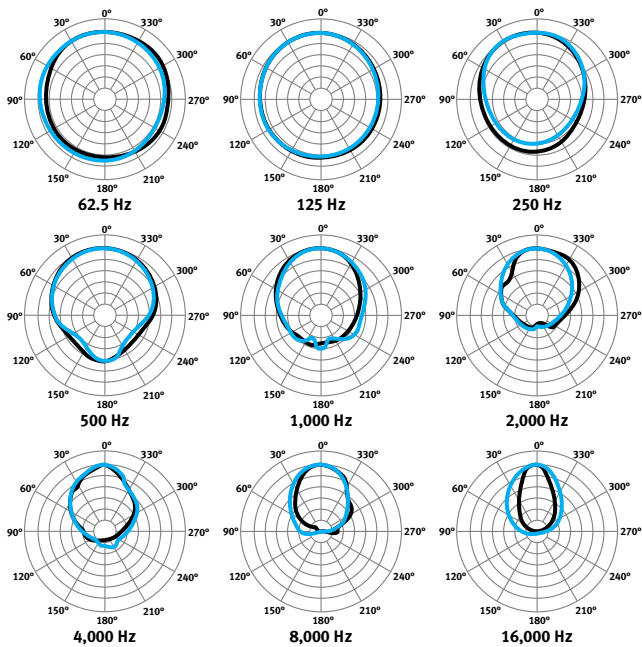

HORIZONTAL ——— All polar measurements obtained in a free-field environment at 10° increments.
VERTICAL ———

FREQUENCY RESPONSE AE-3S2 (with controller)

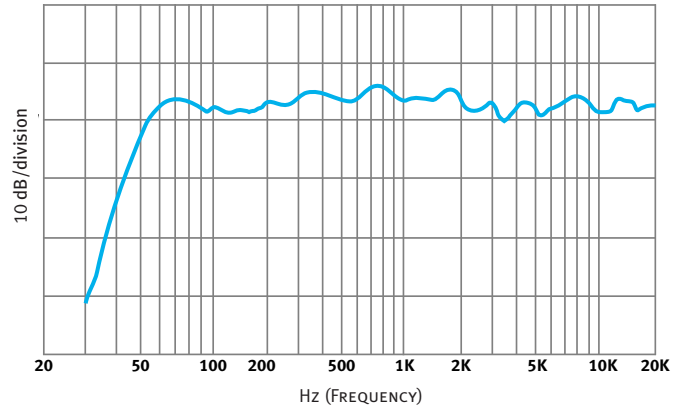

Measured in a free-field anechoic environment using a swept one-third octave input.

PROCESSOR NOTES:

The DLC24 Digital Loudspeaker Controller is a digital engine with an analog surface. It combines the most advanced technology available with intuitive interfaces to provide the key elements that ensure optimal loudspeaker system performance and management in a variety of live sound and fixed installation applications.

The controller provides factory-set equalization curves to smooth the response, protective limiting, and active crossovers (for bi-amplified models and subwoofers).

DIMENSIONAL DRAWINGS AE-3S2 (dimensions in inches and millimeters)

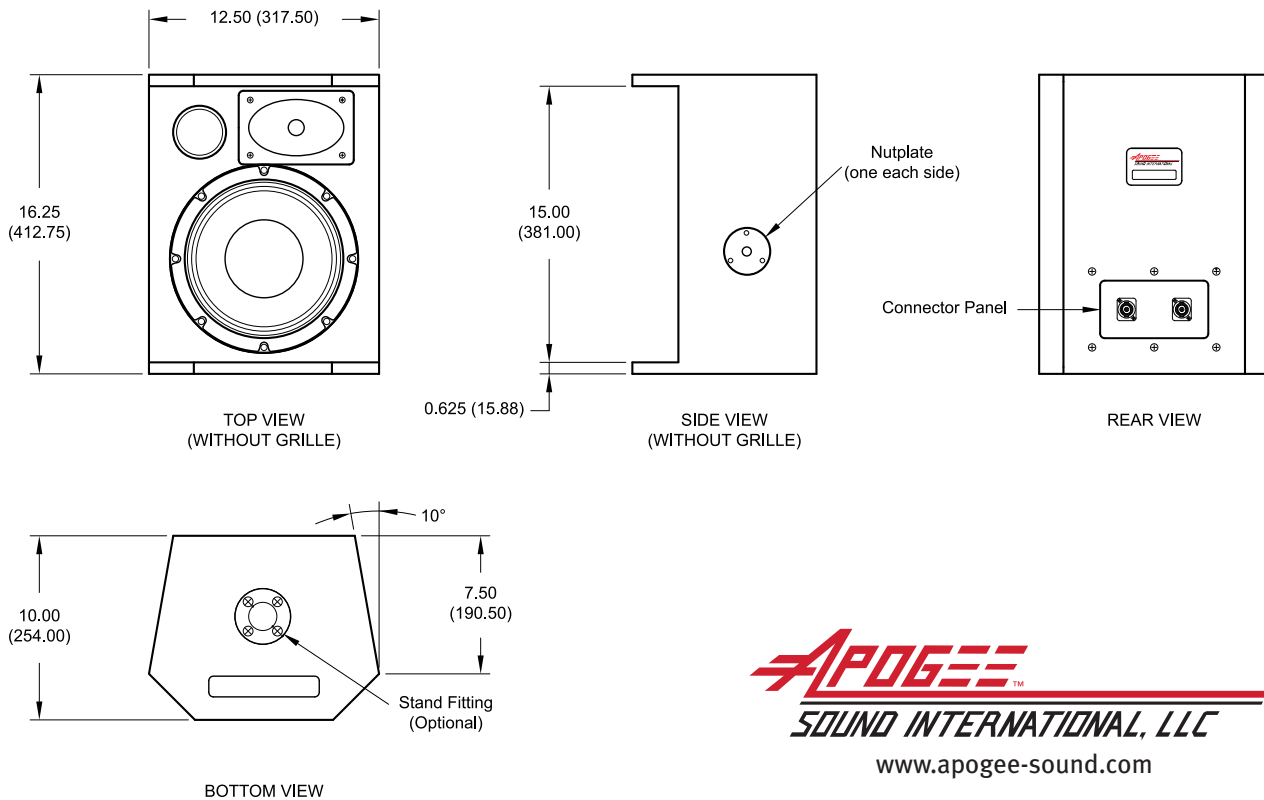

APOGEE
SOUND INTERNATIONAL, LLC
www.apogee-sound.com